

MCEKITC Connector Kit for MCE100C Micro-electrode Amplifier

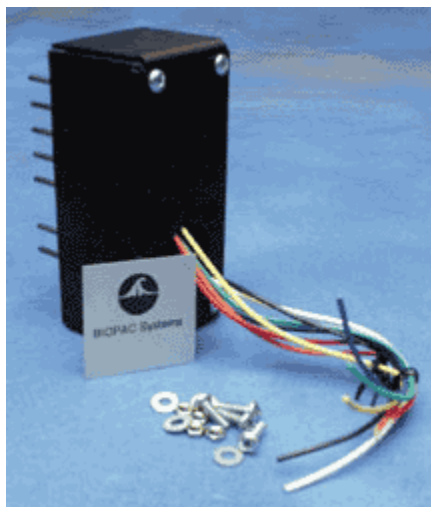

Build a customized adapter to a micro-electrode shielded cable. Cable shields can be tied to voltage follower drive or simply grounded. Input capacity compensation and clamp current options can be independently added to or removed from a cable configuration. The MCEKITC comes with seven attached Touchproof sockets (1.5 mm) and instructions.

The MCEKITC is a junction box assembly that plugs directly into the front panel of the MCE100C amplifier. The MCEKITC comes equipped with an assortment of wire and coaxial cable to customize the MCE100C for a variety of micro-electrode lead connectors. The MCEKITC construction allows you to mount the appropriate interface connector to the housing and solder wires to the respective socket pins.

The MCEKITC is required when either of the last two MCE100C operational modes (5, 6) are used with micro-electrodes. The following table illustrates the configuration desired. The amplifier configuration is determined via the MCEKITC. The MCEKITC connects to the MCE100C and modifies the MCE100C appropriately. See the respective figure to determine the correct MCEKITC configuration for your application.

INPUT TYPE	SHIELD	CURRENT CLAMP	NEGATIVE CAPACITY	MCEKITC FIGURE
Differential	Grounded	No	No	A
Differential	Driven	No	No	B
Single-ended	Grounded	No	No	C
Single-ended	Grounded	No	Yes	D
Single-ended	Grounded	Yes	Yes	E
Single-ended	Driven	Yes	Yes	F

MCEKITC LEGEND

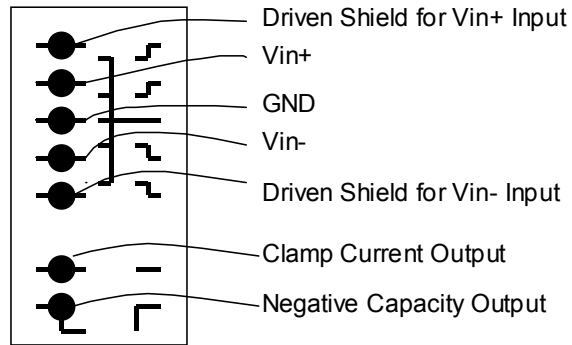

MCEKITC CONFIGURATIONS

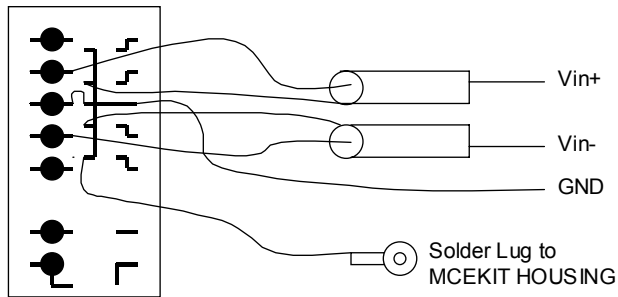

FIGURE A

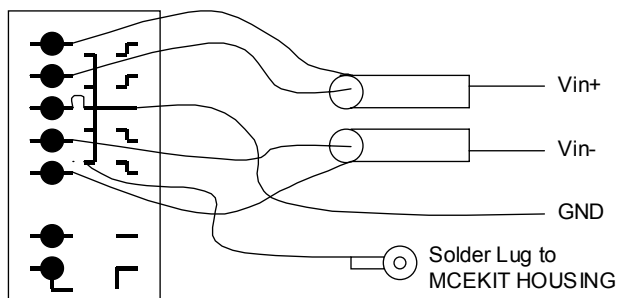

FIGURE B

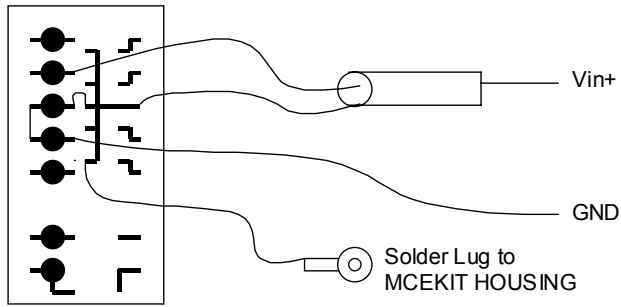

FIGURE C

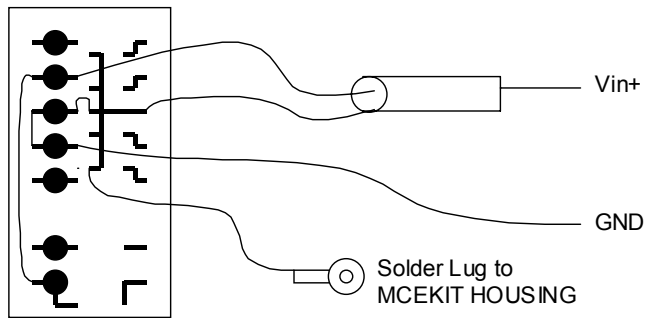

FIGURE D

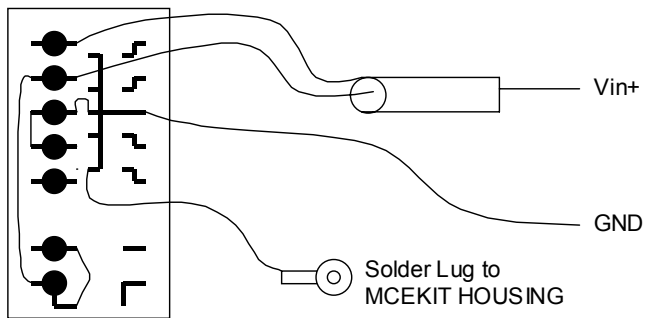

FIGURE E

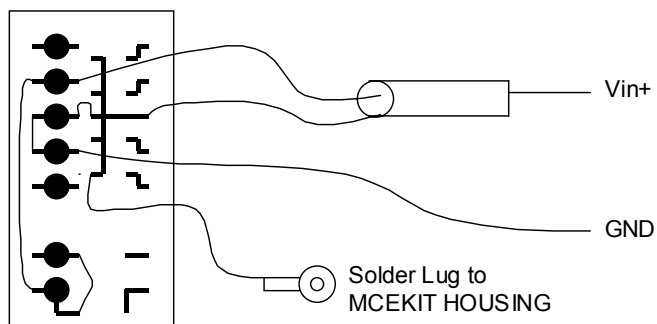

FIGURE F