



# FOTS100

## User Manual

(Orange protective  
boot not included)

BIOPAC Systems, Inc.  
42 Aero Camino, Goleta, CA 93117  
Tel (805) 685-0066, Fax (805) 685-0067

[WWW.BIOPAC.COM](http://WWW.BIOPAC.COM)

## **WARRANTY**

All products manufactured by Opsens inc. are warranted to be free of defects in workmanship and materials for a period of one year from the date of shipment. No other express warranty is given, and no affirmation of Seller, by words or actions, shall constitute a warranty. SELLER DISCLAIMS ANY IMPLIED WARRANTIES OF MERCHANTABILITY OR FITNESS FOR ANY PARTICULAR PURPOSES WHATSOEVER. If any defect in workmanship or material should develop under conditions of normal use and service within the warranty period, repairs will be made at no charge to the original purchaser, upon delivery of the product(s) to the factory, shipping charges prepaid. If inspection by Opsens or its authorized representative reveals that the product was damaged by accident, alteration, misuse, abuse, faulty installation or other causes beyond the control of Opsens, this warranty does not apply. Service, repairs or disassembly of the product in any manner, performed without specific factory permission, voids this warranty.

OPSENS MAKES NO WARRANTY OF ANY KIND WITH REGARD TO THIS MANUAL, INCLUDING, BUT NOT LIMITED TO, THE IMPLIED WARRANTIES OF MERCHANTABILITY AND FITNESS FOR A PARTICULAR PURPOSE. Opsens shall not be liable for errors contained herein or for incidental or consequential damages in connection with the furnishing, performance, or use of this material.

This warranty does not apply to the transducers sold for use with Opsens' signal conditioners.

## **IMPORTANT NOTICE**

The product specifications and other information contained in this manual are subject to change without notice.

Opsens has made a concerted effort to provide complete and current information for the proper use of the equipment. If there are questions regarding this manual or the proper use of the equipment, contact BIOPAC Systems, Inc. at:

TEL 805-685-0066

FAX 805-685-0067

WEBSITE

E-MAIL

[www.biopac.com](http://www.biopac.com)

[info@biopac.com](mailto:info@biopac.com)

## **PACKAGING FOR SHIPMENT**

If the product must be shipped to a different location or returned to BIOPAC for any reason through a common carrier it must be properly packaged to minimize risks of damage.

## **SOFTWARE LICENSE AGREEMENT**

This product contains intellectual property, i.e. software programs, that are licensed for use by the end user/customer (hereinafter "end user").

This is not a sale of such intellectual property.

The end user shall not copy, disassemble or reverse compile the software program.

The software programs are provided to the end user "as is" without warranty of any kind, either express or implied, including, but not limited to, warranties of merchantability and fitness for a particular purpose. The entire risk of the quality and performance of the software program is with the end user.

## WARNINGS



**WARNING: NOT EXPLOSION PROOF!**

Installation of this instrument in an area requiring devices rated as intrinsically safe is not recommended.



**WARNING: VOLTAGE SUPPLY!**

Use only the wall plug-in power supply delivered with your FOTS100 and verifies that the input voltage and frequency are compatible with the power outlet.

## Table of content

<i>Table of content</i>	4
<b>1. Quick start</b>	<b>5</b>
1.1 <i>FOTS100 Powering</i>	5
1.2 <i>Sensor connection</i>	5
1.3 <i>FOTS100 output readings</i>	6
<b>2. Local Operation</b>	<b>7</b>
2.1 <i>Keyboard</i>	7
2.1.1 Switch on/off	7
2.1.2 Menu Button	7
2.1.3 Left/Right Arrows	7
2.1.4 Up/Down Arrows	7
2.1.5 Confirmation button	7
2.1.6 Log button	7
2.2 <i>System Setting</i>	7
2.2.1 Averaging mode	7
2.2.2 Analog output	8
2.2.3 Units	8
2.3 <i>System Diagnostic</i>	8
2.4 <i>Setting the averaging measurements (Menus levels)</i>	10
2.5 <i>Setting the analog output (Menus levels)</i>	11
2.6 <i>Setting the temperature units (Menus levels)</i>	12
2.7 <i>Diagnostic (Menus levels)</i>	13
<b>3. Remote control operation</b>	<b>14</b>
<b>4. FOTS100 specifications</b>	<b>15</b>

## 1. Quick start

### 1.1 FOTS100 Powering

Connect the plug-in wall or tabletop power supply to a power outlet. Verify that the power supply complies with the voltage and frequency outlet. Connect the power cable to the FOTS100 power connector (Figure 1).

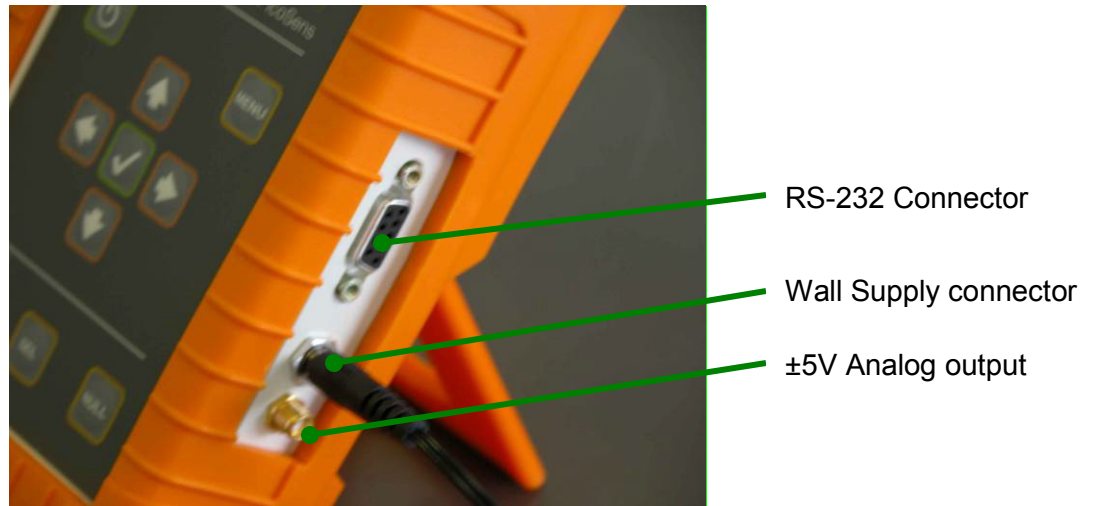
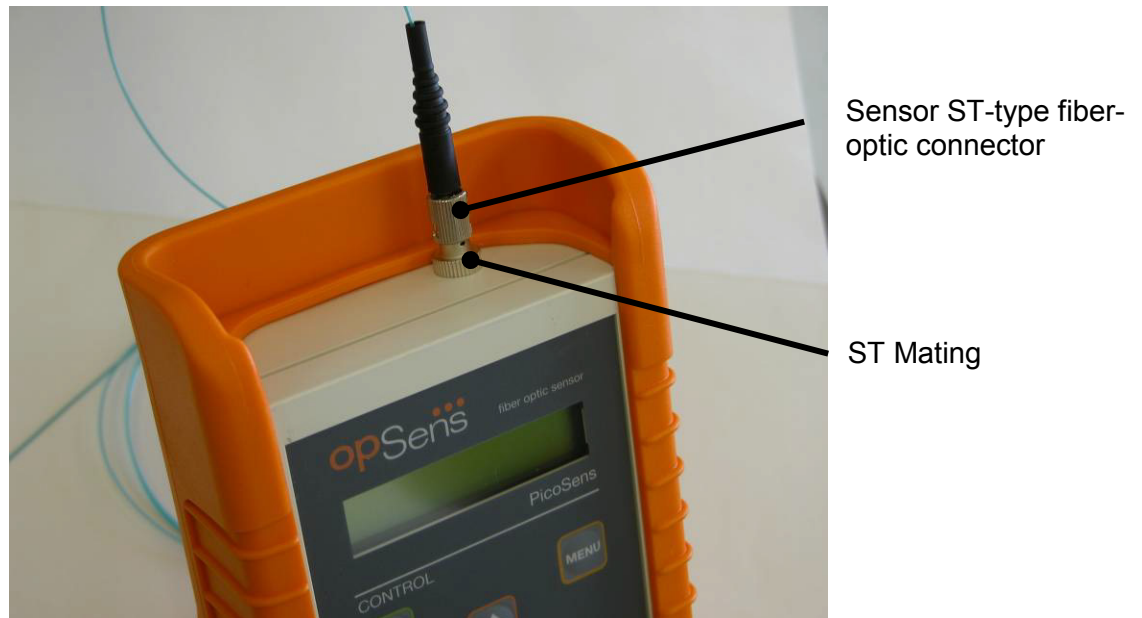

**Figure 1 : Electrical connectors (orange protective boot not included)**

### 1.2 Sensor connection

The FOTS100 is compatible with all TSD180 series Opsens' GaAs-type of sensors or transducers for measuring temperature namely the OTG-M series. The fiber-optic connector provided with the OTG-M sensors is a ST-type connector. Remove the protective cap of the FOTS100 ST mating and engage the sensor connector with the orientation key properly oriented (Figure 2). It is a good practice to clean the sensor connector prior to connect it to the signal conditioner. See the TSD180/181 Fiber-Optic Cleaning Guide for further information on how to clean fiber-optic connectors.

**NOTE: always replace the protective dust cap on the mating when there is no sensor connected. Always replace the protective dust cap on the sensor fiber-optic connector when not in used**



**Figure 2: Fiber-optic sensor connection (orange protective boot not included)**

### 1.3 FOTS100 output readings

Once the fiber-optic sensor is connected, the FOTS100 is ready to measure temperature. The display shows the temperature measurements with a refreshing rate of three readings per second. The measurement readings are also available at the analog output and at the RS-232 port. The refreshing rate of these outputs is equal to the sampling rate of the conditioner, which is 50 measurements per second.

## 2. Local Operation

### 2.1 Keyboard



#### 2.1.1 Switch on/off



The FOTS100 is switched on/off with this button.

#### 2.1.2 Menu Button



Menu button gives access to the system menus. Once in the menu, this button brings the user one level higher into the menu hierarchy. Once at the root, the system will exit the menu and goes back to measurement display.

#### 2.1.3 Left/Right Arrows



Left/Right arrows allow moving from one digit to the other when a value is being entered.

#### 2.1.4 Up/Down Arrows



Up/Down arrows allow navigating 1) between menu items of a given hierarchical level, or 2) it allows changing a value being entered.

#### 2.1.5 Confirmation button



Confirmation button permits confirming 1) a new value being entered, 2) confirm the selection of a menu item then moving one hierarchical level lower, 3) refreshing displayed value in the case of diagnostic.

#### 2.1.6 Log button



(Reserved for future use)

## 2.2 System Setting

The functions below are used to setup specific parameters of the FOTS100.

### 2.2.1 Averaging mode

The user can set ON or OFF the averaging mode (ON by default). When on, the measurements either displayed on the front panel display, output on the analog output or on the RS-232 port is the result of the average of twenty sequential measurements

based on the mobile averaging method. So even when averaging takes place, the output on the analog output is refreshed at a rate given by the sampling rate of the FOTS100. Note that the front panel display is refreshed a rate of three measurements per second. The method to set the averaging is described in Figure 3. This parameter is not saved so the instrument returns to its default state (Averaging ON) after being switched off.

### 2.2.2 Analog output

The analog output parameters comprise the scale factor and the offset. The scale factor corresponds to the physical unit per Volt (unit/V) outputted by the system, while the offset corresponds to the physical value at which the user wants the analog output to be at zero volt. For example, with a scale factor set to 10 °C / V and the offset set to 5 °C, the temperature as a function of the analog output voltage is given by:

$$\text{Temperature} = [\text{Voltage output}] \times 10 \text{ °C / V} + 5 \text{ °C.}$$

The default value of the scale factor is 50 °C / V (or its equivalent in °F) and the default value of the offset is 0 °C (or its equivalent in °F). NOTE: The analog output during a NO SIGNAL condition (see section 2.3) is always set to zero volt.

The method to change the analog output parameters is described in Figure 4. Any new scale factor and offset are saved in the non-volatile memory.

### 2.2.3 Units

The user can set the temperature units in degree Celsius (default value) or in degree Fahrenheit. The method to change the units is described in Figure 5.

## 2.3 System Diagnostic

The user can look through a variety of FOTS100 internal parameter for diagnosing potential problem with the system as described in Figure 6. The available diagnostics parameters are shown below. Diagnostic values can be refreshed by depressing confirmation button .

Parameter and unit values	Description
Lm %	Lamp driving level
Lg Volts	Light level
Sg (no units)	Signal amplitude

The following table shows diagnostic values with good signal, poor signal, or with a broken sensor (“fault”). A fault condition results in a “No Signal” being displayed.



Parameter	Good signal	Poor Signal	Fault
Lm	< 90 %	> 90 %	—
Lg	> 2.2	< 2.2	—
Sg	> 6 000	< 6 000	< 4 000

**NOTE:** Without a sensor connected, the instrument shows the message “NoS” or “No Signal” on its display.

In the unlikely situation that this message appears while a sensor is connected to the unit, take note of the diagnostic parameters and contact BIOPAC technical support.

During a No Signal condition, the analog output and the serial ports output constant values as follow:

Output	No Signal condition output value
Analog	0 Volt
RS-232	65 536.0

There are certain circumstances (i.e. when using some remote control programs) where it is not desirable to have these above constant outputted on serial ports or analog output. Turning OFF the No Signal functionality will prevent this situation.

## 2.4 Setting the averaging measurements (Menu levels)

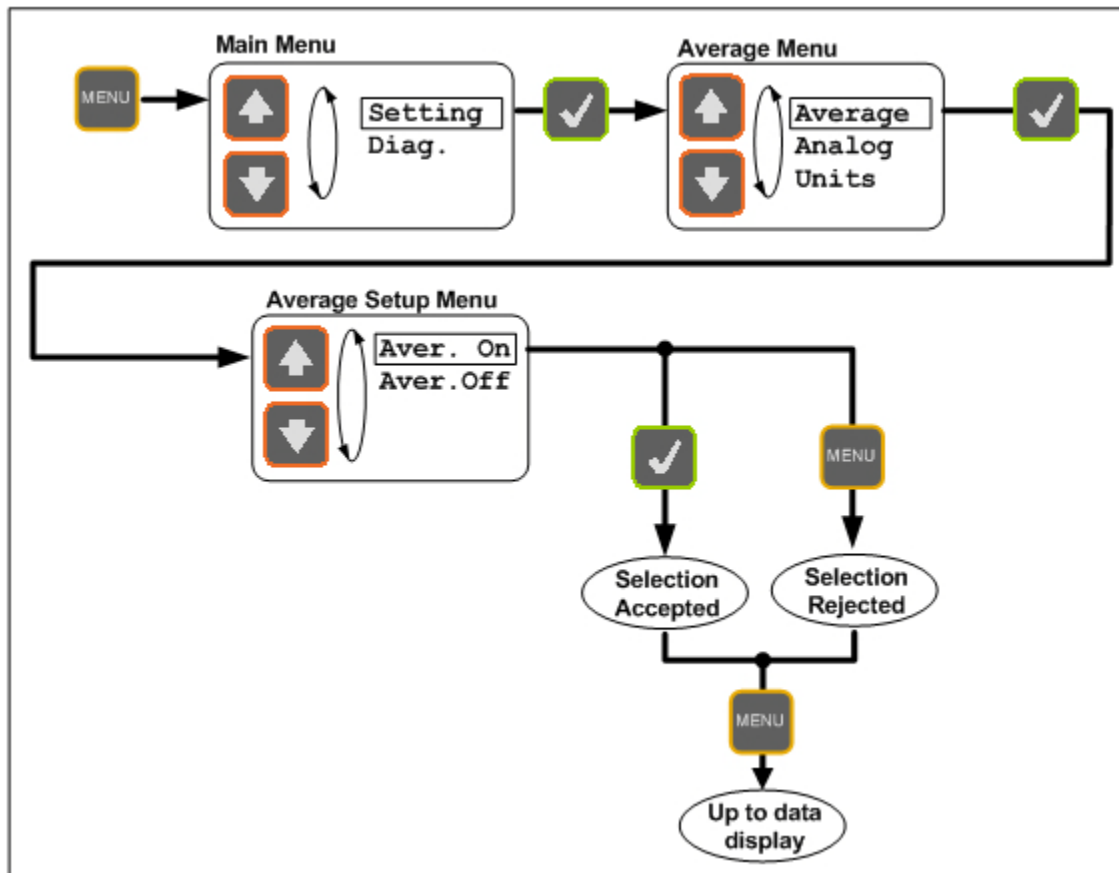

**Figure 3: Averaging measurements**

- Averaging: twenty sequential measurements are averaged for obtaining even smoother signal.

## 2.5 Setting the analog output (Menu levels)

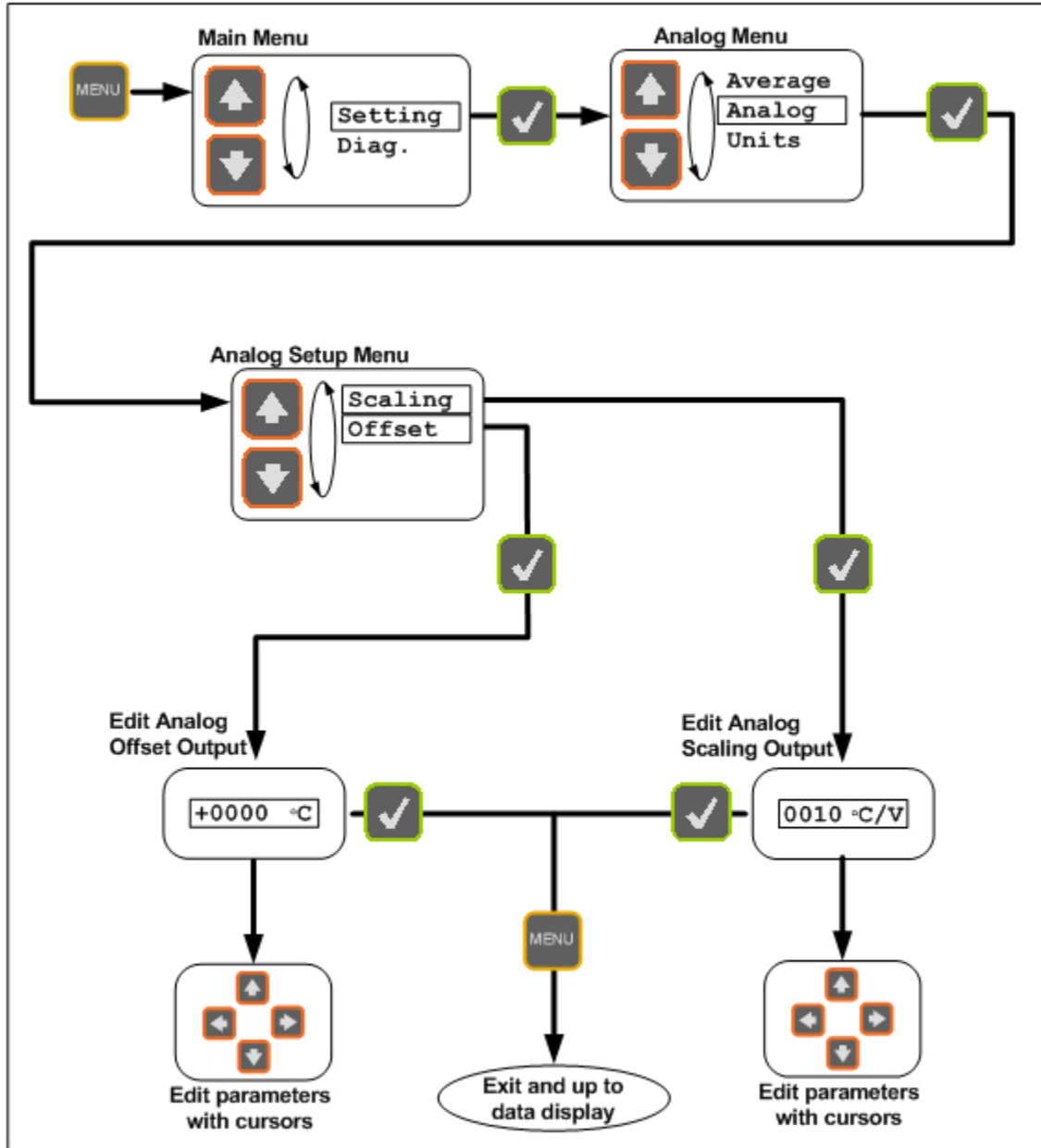

**Figure 4: Setting up the analog output**

- Both the scale factor and offset can be setup according to user requirements.

## 2.6 Setting the temperature units (Menu levels)

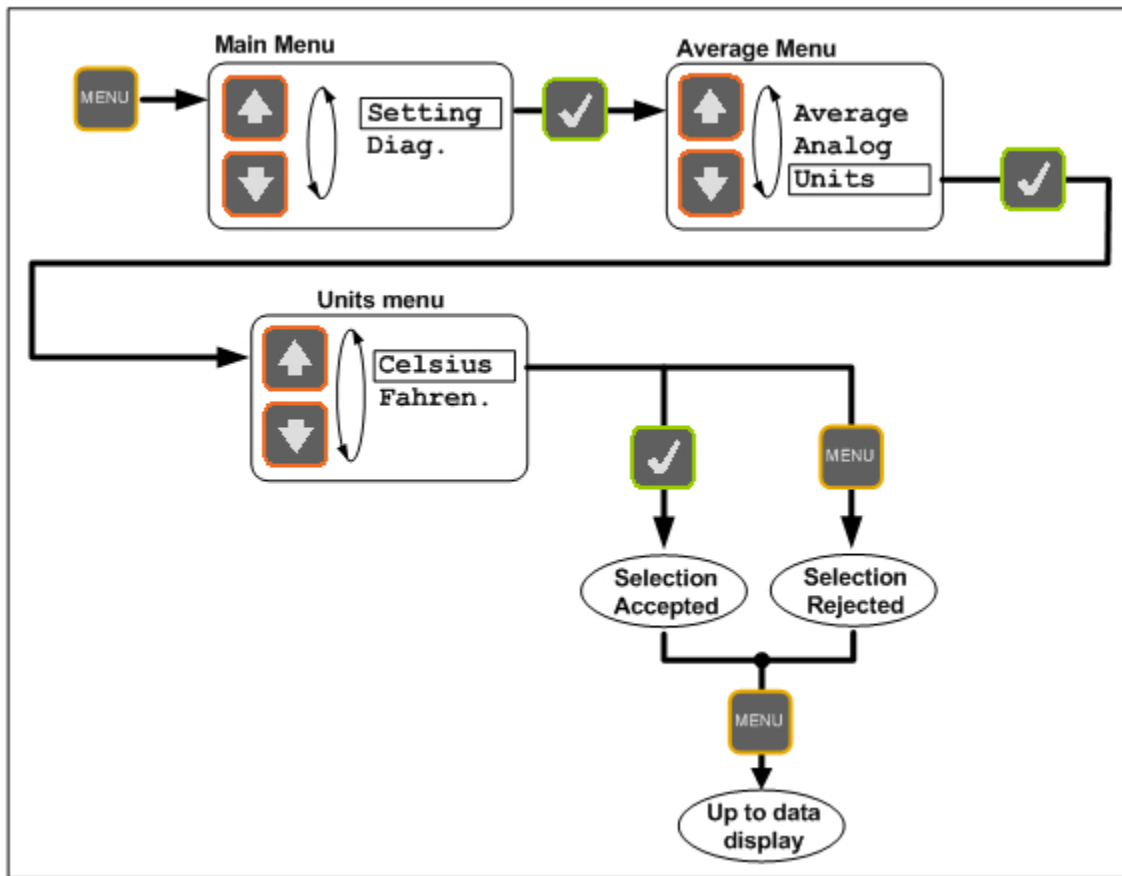

**Figure 5: Setting the temperature units**

- The temperature units can be set to degree Celsius or to degree Fahrenheit

## 2.7 Diagnostic (Menu levels)

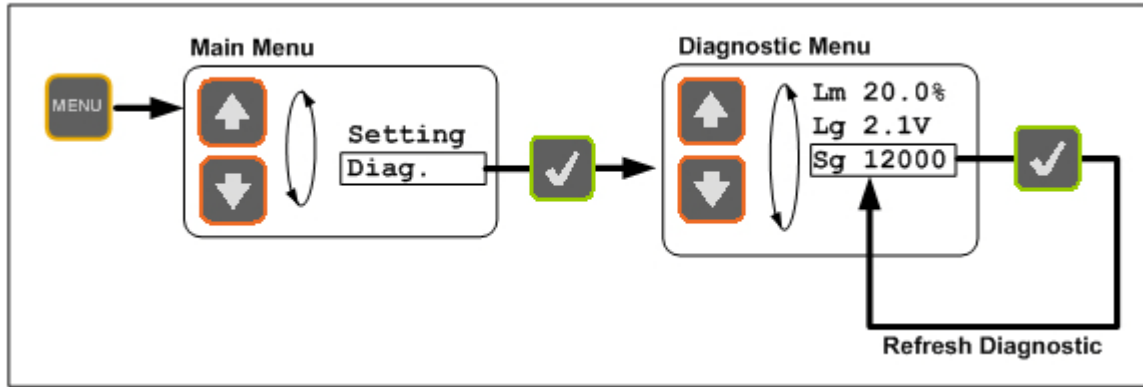

**Figure 6 : Diagnostic**

- The user can look through a variety of diagnostic parameters for diagnosing potential problem with the FOTS100 or the fiber-optic sensor. The available diagnostic parameters are as follows.

Parameters	Description
Lm 20.0%	Lamp driving level
Lg 2.1V	Light level
Sg 12000	Signal amplitude

### **3. Remote control operation**

Opsens FOTS100 signal conditioner uses serial communication to allow control with a remote computer.

The user can create its own remote control software using the various SCPI commands available for the FOTS100. But for ease of operation, Opsens provides its own control software, called SoftSens, which gives access to all the functionalities of the FOTS100 conditioner. See SoftSens user manual for how to remotely control the FOTS100 conditioner.

For those who wish to develop their own remote control software, ask for Opsens SCPI Serial communication user manual to get all the information about serial interfacing with the FOTS100 signal conditioner.

## 4. FOTS100 specifications

Number of channels	One
Compatibility	OTG-M High accuracy GaAs temperature sensor from Opsens
Accuracy	$\pm 0.2^{\circ}\text{C}$ (Total accuracy – from $20^{\circ}\text{C}$ to $45^{\circ}\text{C}$ includes both signal conditioner and transducer errors)
Temperature range	$20^{\circ}\text{C}$ to $45^{\circ}\text{C}$ (higher range also available)
Resolution	$0.1^{\circ}\text{C}$
Sampling rate	50 Hz (20 ms)
Output interface	Display, $\pm 5$ Volts and RS-232 standard
Communication protocol	SCPI (default)
Input power	9 to 24 VDC, positive is center pin (12 V AC/DC wall-transformer adapter included)
Consumption	1.8 Watts typical
Enclosure	Plastic casing
Dimensions	45 mm (H) x 105 mm (W) x 165 mm (L)
Storage temperature	$-40^{\circ}\text{C}$ to $65^{\circ}\text{C}$
Operating temperature	$0^{\circ}\text{C}$ to $45^{\circ}\text{C}$
Humidity	95% non condensing
Light source life span	> 150 000 hours (> 17 years) MTBF